

## **WARNING STUMP GRINDER**

Any piece of equipment can be dangerous if not operated properly. **YOU** are responsible for the safe operation of this equipment. The operator must carefully read and follow any warnings, safety signs and instructions provided with or located on the equipment. Do not remove, defeat, deface or render inoperable any of the safety devices or warnings on this equipment. If any safety devices or warnings have been removed, defeated, defaced or rendered inoperable, **DO NOT USE THIS EQUIPMENT!!!**

**DANGER:** Use extreme caution: The carbide cutters are very sharp! Keep your hands and feet clear of the cutters at all times.

**Do not** tape down or otherwise by-pass any safety devices! Always operate this equipment from the designated operator's position.

**<<< Stump Grinder weighs 134 pounds >>>**

Your Dosko grinder is intended for outdoor-use only & can be used to remove many tree stumps and exposed root systems close to ground level. By moving the blade in sweeping movements laterally over the top & front of the stump, you can gradually grind it away. Make sure you completely read & understand this manual before using the grinder for the first time.

### **WARNING**

**READ & UNDERSTAND** this manual completely before using the grinder! Failure to properly operate, & maintain this grinder could result in serious injury or death to the operator or bystanders.

All machines have hazards associated with their operation. This stump grinder has certain special hazards, which you must be aware of. As an operator or owner, you have a duty to be aware of these hazards & know preventive measures to take to avoid them. When reading this manual pay particular attention to avoiding these hazards. In particular, be aware of the following:

- Know location of buried electrical and other utility lines.
- Be prepared for machine "kickback" when initially contacting the stump.
- Wear eye protection & other personal protection against flying rocks & debris.
- Check that cutter wheel teeth are secured, sharp & not missing.
- Do not operate if operator presence bar fails to stop engine upon release.
- Protect cars, windows & other objects within 75 feet from flying debris.
- Make sure no children or bystanders are within 75 feet of stump grinding operation.
- Do not allow children or untrained adults to operate.
- Be aware of potential for carbon monoxide (CO) poisoning.
- Prevent fires/explosions from fueling.
- Do not attempt to perform adjustments, unclog, or clean unit while engine is running.
- Avoid burns from engine or hot exhaust.
- Avoid using in wet or icy conditions where falls may occur.

## Hazard Signal Word Definitions:





|   |   |
|---|---|
|  | <p>This is the safety alert symbol. It is used to alert you to potential personal injury hazards. Obey all safety messages that follow this symbol to avoid possible injury or death.</p> |
|  | <p>DANGER (red) indicates an imminently hazardous situation which, if not avoided, will result in death or serious injury.</p>  |
|  | <p>WARNING (orange) indicates a potentially hazardous situation which, if not avoided, could result in death or serious injury.</p>   |
|  | <p>CAUTION (yellow) indicates a potentially hazardous situation which, if not avoided, may result in minor or moderate injury.</p>  |
|  | <p>CAUTION (yellow) used without the safety alert symbol indicates a potentially hazardous situation which, if not avoided, may result in property damage.</p>                            |

fig01453



## Owner/Operator/Renter Training

Read and follow all instructions and safety precautions presented throughout this manual. A summary of important safety information can be found at the end of the manual. Keep this manual for reference and review. **If the owner of this unit is different than the operator, give a copy of this manual to any operator to read.**

## Product Suitability

Before using, the user shall determine the suitability of this product for this intended use and assumes liability therein.

Your Dosko grinder can be used to remove many tree stumps and exposed root systems close to ground level. By moving the blade in sweeping movements laterally over the top and front of the stump, you can gradually grind it away. Make sure you completely read and understand this manual before using the grinder for the first time. If you have any questions, contact your retail or rental dealer or Dosko Customer Service at 1-800-822-0295.

## **WARNING: Never attempt to cut on a slope exceeding 15 Degrees.**

Exercise caution when cutting stumps on an incline, as the machine may shift or slide unpredictably. Never attempt to cut with the machine uphill or downhill from you as it may slide toward you or you may fall toward the machine. Cut only on a slope from the side.

## PRE-START CHECK LIST & PROCEDURES

**CAUTION:** Add engine crankcase oil. A new engine is shipped without oil. You must add the correct amount of oil to engine crankcase or engine will be damaged beyond repair.

Before starting the engine, you will want to make sure you have completed the following:

1. Marking Underground Utilities
2. Checking Controls
3. Checking Cutting Teeth
4. Checking/Adding Oil
5. Filling Stump Grinder Gasoline Tank
6. Inspecting Fuel System for Leaks
7. Locking Handlebar
8. Wearing Personal Protection
9. Trimming Stump with Saw
10. Clearing Area of People and Objects
11. Working During Daylight

Each of these procedures is discussed in detail below.

## **MARKING UNDERGROUND UTILITIES**

Call 811 or your local utility company to request marking utilities 3 days before stump grinding. Trees can grow on top of and around underground wiring that was installed many years before a tree was planted.

Check controls.

Check that:

- All guards are in place and tight.
- Operator presence bar switch is free moving.
- Inspect tires and rims for looseness, damage, and tire inflation.

Check cutting teeth:

Inspect cutting teeth for tightness and sharpness. Only use factory-approved parts for repair.

Check/add oil:

Check the oil level using the dipstick and add oil as needed.

**WARNING:** Burn hazard Never open oil fill port while engine is running. Hot oil can spray over face and body.

Fill stump grinder gasoline tank: Check the gasoline level in the engine's fuel tank. If needed, fill tank with fresh unleaded gasoline from a portable container, after first reading the warnings and instructions below.

**Do NOT** fill the gas tank to the top. Gasoline may spill when operating on a slope.

**Do NOT** overfill the gasoline tank. Allow at least 1" of empty space below the fill neck to allow for fuel expansion.

**WARNING:** Gasoline fire/explosion hazard Gasoline is highly flammable and explosive. Heat, sparks, and flames can ignite gasoline vapors, which can become widespread during fueling. A flash fire ignition and/or explosion could result and cause serious injury or death. The following conditions could result in gasoline ignition/explosion:  gas vapor collection inside enclosures  static electric sparks  sparks from electric wiring, batteries, or running engines  sources of heat (such as a hot engine or exhaust)  open flames, including pilot lights.

Inspect Fuel System / Check for Leaks:

Inspect fuel system & check for leaks **BEFORE** starting grinder.

**WARNING:** Fuel leak hazard: A leaking fuel line, no matter how small, can be the source of a fire or explosion when starting or operating the engine.

Inspect the entire fuel system. Look for: Signs of leaks or deterioration, chafed or spongy fuel hose, loose connections, loose or missing fuel hose clamps, damaged gasoline tank, or defective gasoline shut-off valve.

If grinder is in an enclosed area and you smell gas, **DO NOT** start engine! **DO NOT** light a match. **DO NOT** flip on an electrical switch. Exit area immediately leaving doors open and call fire department.

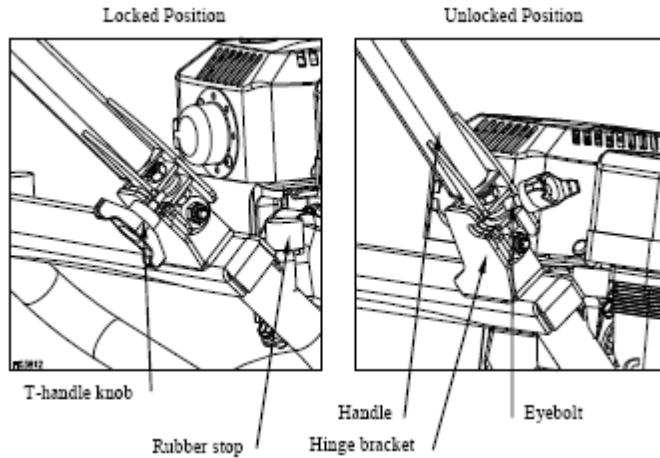

### **LOCKING HANDLEBAR**

Handle is capable of folding when not in use.

To lock handle into place:

- Position T-handle knob and eyebolt so it is on the back side of the hinge bracket.
- Tighten T-handle knob finger tight.
- Repeat on other side

To fold handle:  Turn T-handle knob counterclockwise to loosen.  Swing knob and eyebolt to the outside, on both sides of handle.

Carefully fold handle downward until it comes in contact with the rubber stops.

### **PERSONAL PROTECTION**

Use approved protective clothing and approved protective equipment when using the machine.

- 1.** Always wear ANSI-approved and OSHA-compliant safety glasses with side shields and a full-face shield.
- 2.** The use of ear plugs, or other hearing protection device is also recommended for persons working within 15-20 feet of the running grinder for longer than a few minutes. Hearing can be damaged from prolonged, close-range exposure to the type of noise produced by this grinder.
- 3.** Wear long pants to protect legs from sparks, hot engine and flying debris.
- 4.** Never wear jewelry or loose-fitting clothing when starting or operating the grinder or any mechanical device. Loose or dangling apparel, jewelry or hair can become entangled in moving parts.

Trim Stump with Saw: Cut or trim the stump preferably to ground level using a power saw.

**Clear Area:** Dig away the earth and remove any stones near the tree stump or roots that may interfere with your work.

Work During Daylight Hours Only use the machine in daylight or in well-lit conditions. Never operate the grinder after dark.

**STARTING THE GRINDER:** After you have completed the pre-start checklist and procedures, you are ready to start the grinder.

**WARNING:** Never attempt to use the grinder without proper protective equipment, particularly eye protection and a full-face shield.

**To start the grinder:** Note: For additional engine starting instructions see your Honda engine manual. **1.** Lock handle in the upright position. **2.** Place stump grinder into position with cutting wheel near the front-top edge of the stump. **3.** Use brake lever on handle to lock the wheel brake. Note: For tighter brake adjustment, turn knob on top of brake lever. **WARNING:** Stay in the OPERATOR POSITION (behind the machine) while actuating controls. Never leave grinder unattended. **4.** For cold engine, move choke lever to the CLOSED position. To restart a warm engine, leave choke lever in OPEN position. **5.** Turn engine switch to the ON position. **6.** Grip operator presence bar and handlebar together in left hand. **WARNING:** A rotating cutting wheel is very dangerous. Stay at the controls and keep others away until you are sure the blade has come to a complete stop. **7.** Pull the starter grip lightly until you feel resistance, then pull briskly. Return the starter grip gently. If the choke lever was moved to the CLOSED position to start the engine, gradually move it to the OPEN position as the engine warms up. **8.** If engine does not start, repeat steps 5-7. **9.** Press down on handlebar to lift cutter wheel off the ground. **10.** Grip throttle control lever and handlebar together in right hand. Centrifugal clutch will engage and cutter wheel will begin to rotate.

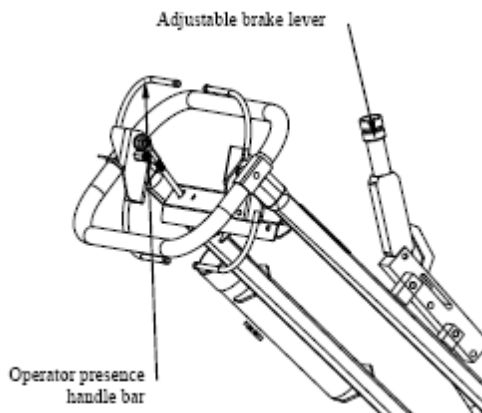
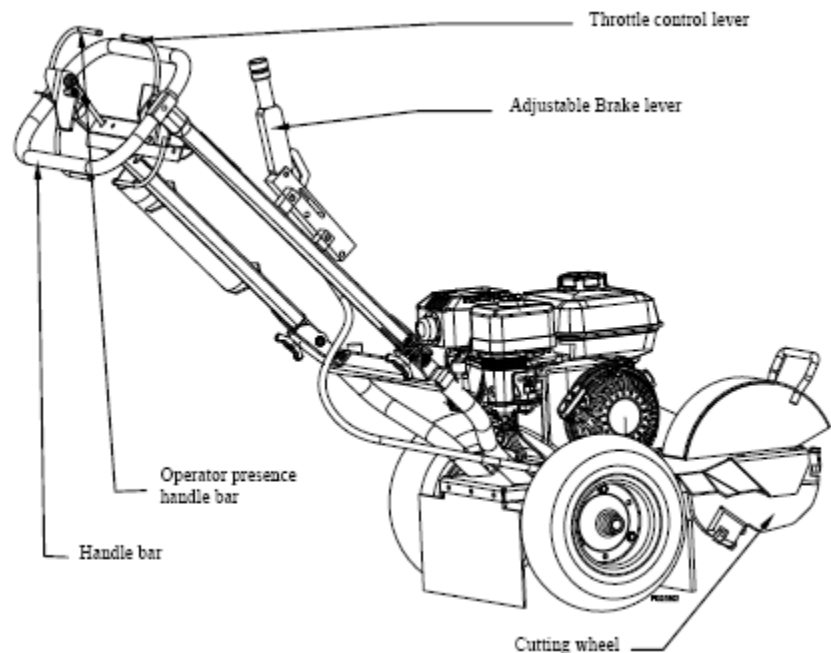

### **Stop the engine using the following steps:**

- 1.** While holding blade off ground, release the operator presence bar. The engine will stop. Wait until the blade completely stops. Lower the blade so it is resting against the ground.
- 2.** Make sure brake is set before leaving the controls, particularly if you are on an incline.
- 3.** Turn engine switch to OFF position.
- 4.** Allow the engine to cool for at least 5 minutes before releasing brake and moving to storage or transporting. A hot engine can be a fire hazard.

## GRINDING THE STUMP

**WARNING:** Flying Debris Hazard Stones, chips, and debris can cause serious injury or property damage. Debris can fly 75 ft in any direction out of the chute. They can bounce off any fixed objects as well and hit operator, bystanders, or breakable objects. **1.** Set/engage the brake. **2.** Pivot the grinder toward the side of the stump, with a fairly light touch feed straight into the stump. As soon as you feed in, start to swing to the side until you feel the wheel drop off the edge of the stump. Change direction and swing back the other way until you feel it reach the other edge of the stump. As you swing to the side listen to the engine. Provide enough feed to give it a moderate load. If you hear any belt or clutch squealing you are pushing too hard. If you can't swing it to the side, raise the grinder up.

You can cut roots off by plunging straight through them.

**WARNING:** Rotating cutter wheel. Keep hands and feet away. Contact with wheel rotating teeth will cause serious personal injury.

*Chip Build-up:* **3.** When grinding larger stumps, chips may begin to build up under the wheels. **4.** Release brake and pull machine towards you so that the "chip pile" is directly under the cutting wheel. **5.** Drop cutter wheel down on "chip pile", material will be discharged from machine area.

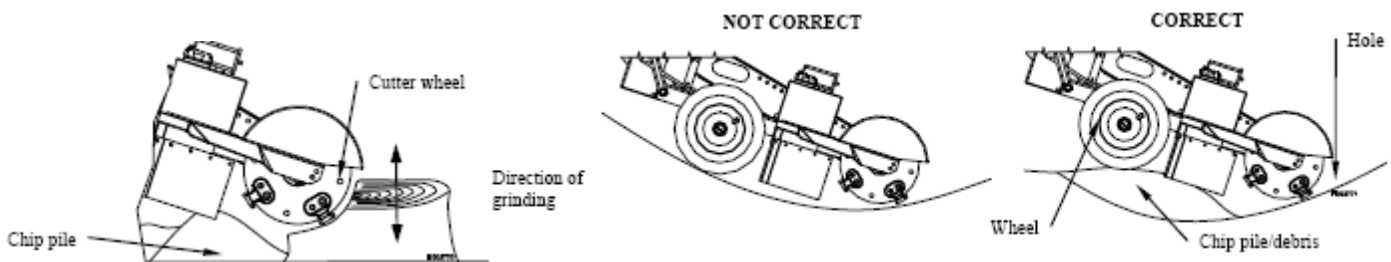

**WARNING:** Flying Debris Hazard Stones, chips, and debris can cause serious injury or property damage. Debris can fly 75 ft in any direction out of the chute. On these larger stumps, **DO NOT** allow grinder wheels to drop into stump hole. If a hole is in the way of your progress, fill it with chips or change position.

**WARNING:** Stop engine and set brake before leaving operator's position. **KEEP BRAKE ENGAGED** except when changing locations. When finished, stop the machine. Pull machine away from stump, and rake chips away from stump.

**⚠️ WARNING:** Operating, servicing, and maintaining this equipment can expose you to chemicals including engine exhaust, carbon monoxide and lead, which are known to the State of California to cause cancer and birth defects or other reproductive harm. To minimize your exposure, avoid breathing exhaust, do not idle the engine except as necessary, operate and service your equipment in a well-ventilated area and wear gloves or wash your hands frequently when servicing your equipment. For more information go to [www.P65warnings.ca.gov](http://www.P65warnings.ca.gov)

If the person receiving this handout will not be the user of the equipment, forward these instructions to the operator. If there is any doubt as to the operation or safety of the equipment, **DO NOT USE!!! CALL A TOOL SHED IMMEDIATELY!!! FAILURE TO FOLLOW THESE INSTRUCTIONS COULD RESULT IN INJURY OR DEATH**